

GX 40 F

Dimensions

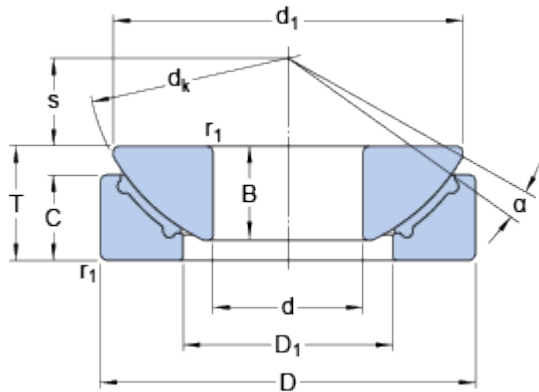

d		40	mm
D		105	mm
T		32	mm
α		6	°
d_k		114	mm
d_1		97	mm
D_1		59	mm
B		27	mm
C		21.5	mm
r_1	min.	1	mm
s		24.5	mm

Abutment dimensions

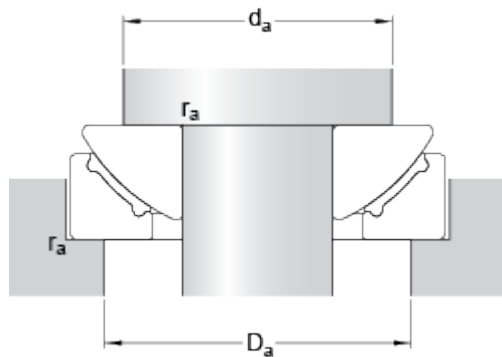

d_a	min.	78	mm
D_a	max.	84	mm
r_a	max.	1	mm

Calculation data

Basic dynamic load rating	C	173	kN
Basic static load rating	C_0	275	kN
Specific dynamic load factor	K	50	N/mm ²
Specific static load factor	K_0	80	N/mm ²
Material constant	K_M	670	

Mass

Mass plain bearing	1.5	kg
--------------------	-----	----